

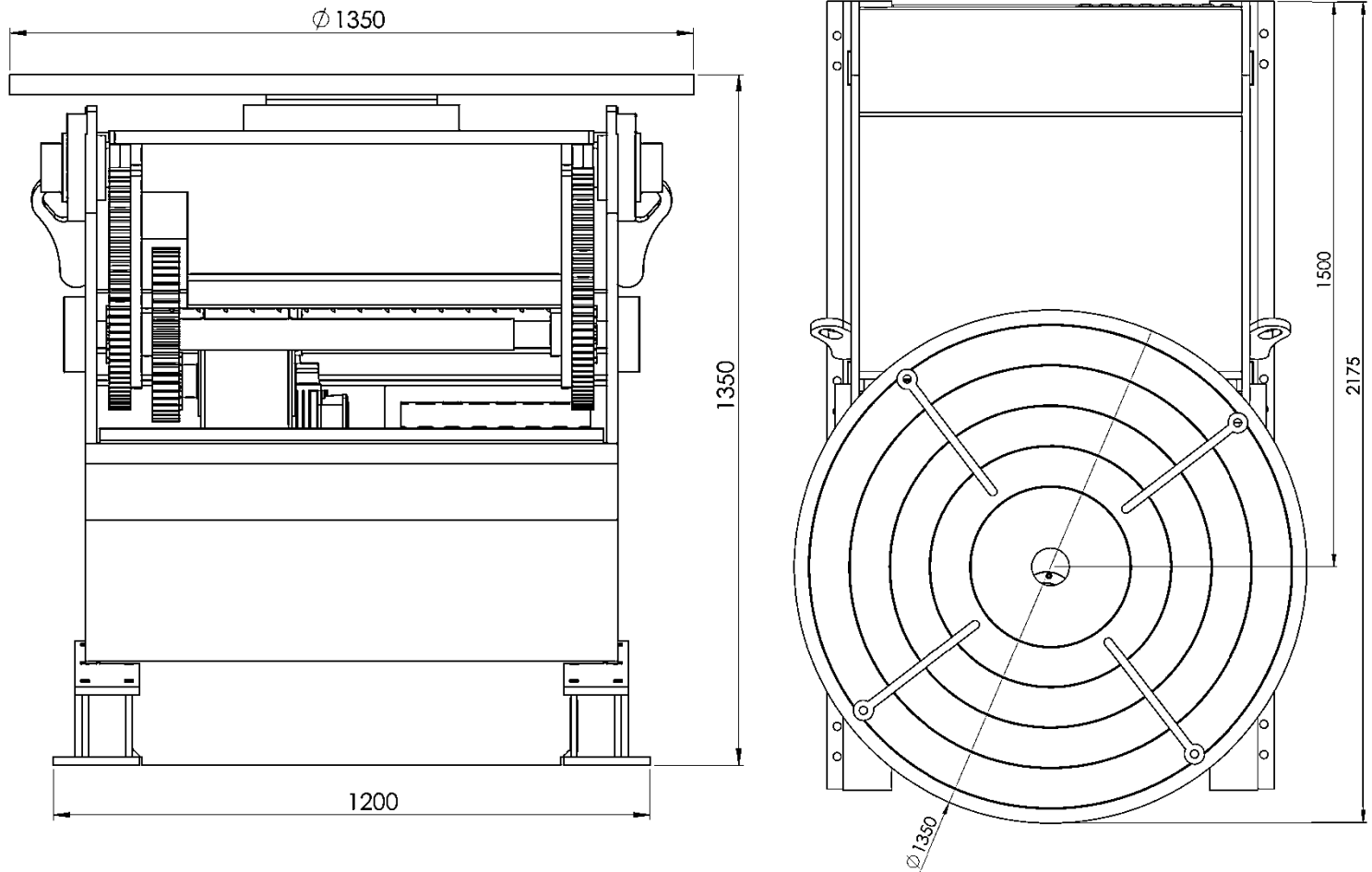

Westermans International Ltd
together we weld the world...

Technical Specifications – WPOZ 5000



Max. Load (N)	50000
Axis Eccentricity	150mm for Rotation and Tilting
Rotation Speed (rpm/min)	Min 0,088 – Max 0,88 at 5 – 50 Hz Range
Rotation Torque (kg.m)	750
Rotation Motor	1 x 2,2 Kw AC Motor
Tilting Angle	120°
Tilting Speed from 0 to 120	150 second
Tilting Torque (kg.m)	1630
Tilting Motor	1 x 1,1 Kw AC Motor
Driver	Yaskawa 3 Kw / 2,2 Kw
Face Plate Diameter	1350 mm
Fixing Slots	8 T-Slots / M18
Control Device	Standing Control Panel
Incoming Supply	380/400V, 3Ph, 50Hz @ 5 – 50 Hz
Applicable Optional	Hand Pendant & Foot Pedal
Colour	RAL6025 GREEN/Texture Painting
Welding Torch Holder	Not Available
Shipping Dimension & Weight	Width 1600mm x Length 3100mm x Height 1700mm / 2500 Kg

Westermans International Ltd
Unit 4, Midland Distribution Centre, Markfield Road, Groby, Leicester LE6 0FS UK
welding@westermans.com www.westermans.com +44(0) 1162 696941